

**MTH 301**  
**Exam 1**  
**Fall 2017**

100 points possible.

1. (8 pts.) Use De Morgan's laws to write the negation for each statement.

(a) This assignment is a collision and this graph is simple.

(b) This loop is correct or Dylan's real name is Zimmerman.

2. (8 pts.) Write the negation for each statement.

(a) If the Mustache Man is in the gallery, then the Judge is Worlock.

(b) If Adam's guitar is available, then Jesse is a photographer or Mickey is a vegan.

**3.** (12 pts.) State whether each argument is valid or invalid. (No justification needed.)

(a) If William shames the music of sweet news, then he plays it with a sour face.

William plays it with a sour face.

$\therefore$  William shames the music of sweet news.

(b) If the topological sorting is finite, then it has a minimal element.

The topological sorting is not finite.

$\therefore$  The topological sorting does not have a minimal element.

(c) If the module has a single invariant, then the module is commutative.

If the module has a basis, then the module is commutative.

$\therefore$  If the module has a single invariant or the module has a basis, then the module is commutative.

4. (8 pts.) A supplemental page shows a circuit (labeled “Problem 4”).

Write the input/output table for the circuit.

$P$	$Q$	$R$	$S$

5. (8 pts.) Perform the addition using binary notation. Your answer should be in binary. (Ideally, you would perform this addition directly in binary, without converting base.)

(a)

$$\begin{array}{r} 1100_2 \\ + 110_2 \\ \hline \end{array}$$

(b)

$$\begin{array}{r} 110010_2 \\ + 10111_2 \\ \hline \end{array}$$

6. (8 pts.) Write a formal negation for each statement.

(a)  $\forall$  semigroups  $G$ ,  $G$  has an identity element.

(b)  $\exists$  a random variable  $X$  such that  $X$  does not have an expected value.

7. (16 pts.) A supplemental page shows a Tarski world figure. Indicate whether the statement is true or false. (No justification needed. Write the whole word “true” or “false.”)

Reminders:  $\text{Triangle}(x)$  means “ $x$  is a triangle.”  $\text{Blue}(y)$  means “ $y$  is blue.”  
 $\text{Above}(x, y)$  means “ $x$  is above  $y$  (but not necessarily in the same column)” ; i.e., “the row  $x$  is in is above the row  $y$  is in.”

(a)  $\forall u, \text{Above}(u, d) \rightarrow \text{Circle}(u)$

(b)  $\exists z$  such that  $\text{Triangle}(z) \wedge \text{Above}(z, g)$

(c)  $\forall$  triangles  $w$ ,  $\exists$  a square  $y$  such that  $\text{Above}(w, y)$ .

(d)  $\exists$  a square  $x$  such that  $\forall$  triangles  $v$ ,  $\text{Above}(x, v)$ .

**8.** (8 pts.) Lewis Carroll Puzzle. Use the following letters (or your own letters) to translate each given premise into symbols. Then deduce a logical conclusion using all given premises. Write your conclusion in symbols and in words.

- (1) I despise anything that cannot be used as a bridge;
- (2) Everything, that is worth writing an ode to, would be a welcome gift to me;
- (3) A rainbow will not bear the weight of a wheelbarrow;
- (4) Whatever can be used as a bridge will bear the weight of a wheel-barrow;
- (5) I would not take, as a gift, a thing that I despise.

Univ. "things"; W = able to bear the Weight of a Wheelbarrow; G = I would welcome/take as a Gift; D = Despised by me; R = Rainbows; B = useful as a Bridge; O = worth writing an Ode to.

**9.** (8 pts.) For each of the given values of  $n$  and  $d$ , find integers  $q$  and  $r$  such that  $n = dq + r$  and  $0 \leq r < d$ .

(a)  $n = 96, d = 22$

(b)  $n = -72, d = 15$

**10.** (8 pts.) Prove. (Prove directly from the definitions.)

The difference of any odd integer minus any odd integer is even.

**11.** (8 pts.) Prove. (Prove directly from the definitions.)

For all integers  $x$ ,  $k$ , and  $j$ , if  $x$  divides  $k$  then  $x$  divides  $jk$ .

AND

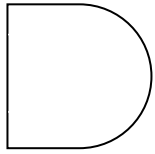

OR

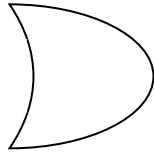

NOT

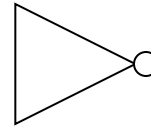

**Problem 4.**

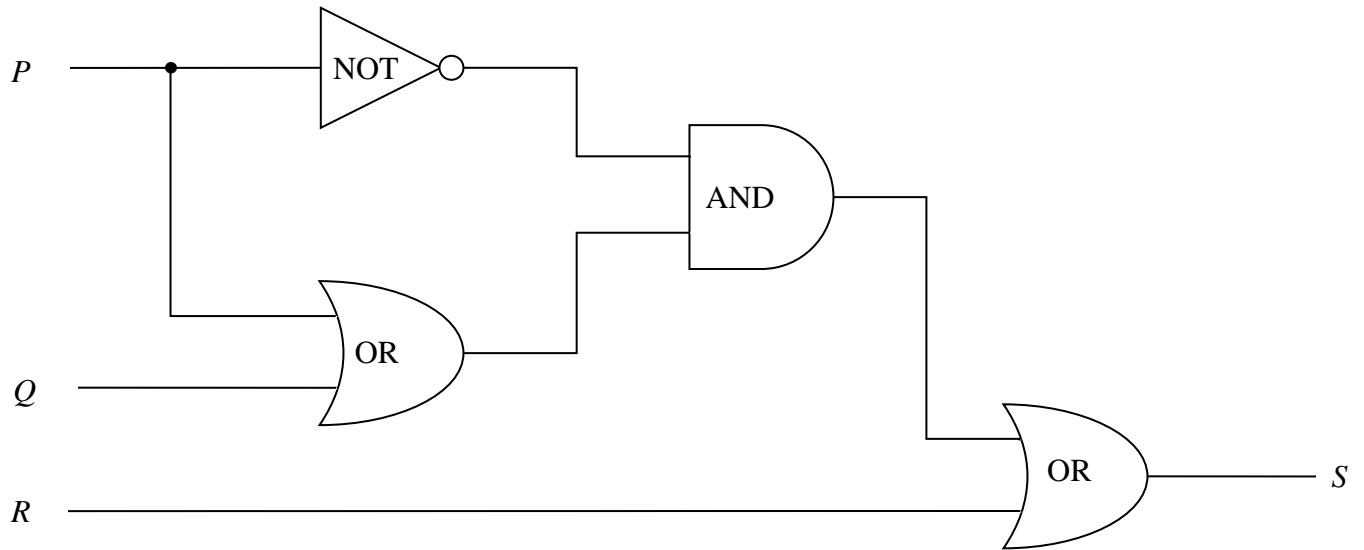

**Tarski World Figure.**

